



**NOT FOR INTRODUCTION UNTIL 01.07.2010
PROPOSED SPECIFICATIONS FOR
STREET SEDANS and
SUPER STREET SEDANS**

INDEX

INTERPRETATION.....	2
GENERAL.....	2
AUTHORITY TO EXCLUDE.....	2
CONSTRUCTION.....	3
MINIMUM SPECIFICATION.....	3
DEFINITIONS.....	3
ANNUAL REGISTRATION.....	3
DECLARATION OF COMPLIANCE.....	3
INSPECTION.....	4
MEASURING OF CARS.....	4
IMPOUND AREA.....	5
PENALTIES.....	5
DRIVER/PASSENGER SAFETY.....	5
SEAT BELTS	5
WINDOW NET.....	8
PADDING	9
FIRE EXTINGUISHER.....	10
TYPE OF SEDANS THAT CAN BE USED.....	10
PARTS TO BE REMOVED FROM BODY.....	10
MODIFICATIONS TO BODY.....	10
IDENTIFICATION NUMBERS.....	12
ROLL CAGE SPECIFICATIONS.....	13
ROLL CAGE CONSTRUCTION.....	13
BARS REQUIRED.....	14
BUMPER BARS	17
VEHICLE RETRIEVAL METHOD	18
OPTIONAL BARWORK.....	18
FRONT/REAR HUBS, AXLES & TAILSHAFT.....	20
REPLACEMENT FUEL TANK AND FUEL SYSTEM.....	21
FUEL LINES AND FITTING.....	21
BRAKES.....	22
PEDAL CLUSTER	22
COOLING SYSTEM.....	22
BATTERY AND ELECTRICAL SYSTEM.....	23
SEATS - DRIVER AND PASSENGER SAFETY.....	24
STREET SEDAN SPECIFICATIONS.....	26
SUPER STREET SEDAN SPECIFICATIONS.....	39
GLOSSARY OF TERMS.....	50

INTRODUCTION

INTERPRETATION

The Q.S.C.A. Inc Technical Committee shall be the sole authority for the interpretation of specifications as contained in this book with circularized amendments. The decision of the Technical Committee shall be binding on all officials, owners and drivers in that area. Any amendments made by the Technical Committee other than safety must be ratified by the Management Committee for implementation.

GENERAL

This section of Speedway racing has been designed as a cheaper form of sedan racing to allow the introduction of enthusiasts into the sport. It is a condition of the section that each car will have a driver and passenger. Each car is to be registered through a Club with the Q.S.C.A. Inc. Both driver and passenger must hold a current relevant Q.S.C.A. Inc. competition Licence.

Before constructing cars of unusual or unconventional design, full details are to be submitted in writing to the Q.S.C.A. Inc State Technical Rep. This submission shall be handled by the Technical Committee and approval or required modification before approval, shall be given in writing to the applicant.

IF IT IS NOT IN THIS SPECIFICATION BOOK, IT CANNOT BE USED.

AUTHORITY TO EXCLUDE:

Notwithstanding anything contained in these specifications, if the State Tech. Rep., the State Technical Committee or the Chief Scrutineer, determines prior to the race that the race car does not meet the applicable specifications, the race car shall not be allowed to compete.

"THE SPECIFICATIONS THAT THE Q.S.C.A. INC ARE USING FOR THIS SPECIFICATION BOOK ARE THOSE SET OUT BY THE MANUFACTURER."

PLEASE REMEMBER

IF IT IS NOT COVERED OR ALLOWED IN THESE SPECIFICATIONS THEN IT CANNOT BE DONE

IF YOU ARE NOT SURE PLEASE CONTACT YOUR CLUB SCRUTINEER OR THE STATE QSCA TECHNICAL DIRECTOR

[**Insert link to website contacts page**](#)

CONSTRUCTION

To be of a professional standard using first grade materials - no downgrade material allowed. All materials quoted are minimum sizes unless a maximum is specifically quoted.

MINIMUM SPECIFICATION

All tubing or pipe used in the main structure of ROLL CAGE and supports must meet the specifications as listed in AS 1163, GRADE 250 or TS21 minimum, whichever is relevant to steel being used.

NO GALVANISED OR PLATED PIPE PERMITTED.

DEFINITIONS:

C.H.S. = CIRCULAR HOLLOW SECTION

R.H.S. = RECTANGULAR HOLLOW SECTION

W.T. = WALL THICKNESS

BEFORE CONSTRUCTING RACE CAR, READ THE SPECIFICATIONS CAREFULLY AND DECIDE WHICH CLASS IS GOING TO SUIT.

If in doubt regarding any of these specifications always consult firstly your Club Chief Scrutineer, Zone Technical Officer or State Technical Representative.

It is better to ask first than have to change something after the car is constructed.

ANNUAL REGISTRATION

A car registered in the immediate past season can be re-registered without a Daylight Inspection only if the car remains registered to the same owner and the log book is not full. The registration of a new car or a car that was not registered in the immediate past season requires a Daylight Inspection.

Before annual registration of car can be applied for the following steps are to be carried out:

- a. Present car for Daylight Inspection - ***only current for 30 days.***
- b. Complete Application to Register Race Car form.

Cars that are re-shelled into the same make and model can continue the same registration but need to have a Daylight Inspection prior to taking part in competition.

Notification must be given to QSCA Inc of re-shelling by lodgment of Daylight Inspection form and return of Log Book for updating.

DECLARATION OF COMPLIANCE

DECLARATION OF COMPLIANCE will cover eligibility for class and ALL points of SAFETY including material specification and sizes. Details of the declaration are to be placed in the logbook. **REGISTRATION IS NOT COMPLETE UNTIL pages 2 - 5 of the log book are completed and signed by the owner/driver and the Scrutineer/machinery examiner. A current season Decal must be affixed to car.**

INSPECTION

Cars must pass a pre-registration examination to receive logbook endorsement. The Club Scrutineer or State Technical Rep can revoke this endorsement at any time if vehicle is found defective. The endorsement may be withdrawn until repair or adjustment has been made and approved.

Driver and/or owner must be present at the time of inspection.

Drivers are responsible for having the logbook endorsed before an official practice session or meeting.

An unendorsed logbook is equivalent to a no-race ticket.

Structural or other specification changes made during the season **MUST** be officially notified and car re-inspected before competing.

MEASURING OF CARS:

All cars are subject to engine compliance measurement at **any** time by the State Technical Rep, the State Technical Committee OR at the direction of the State Technical Representative, or the State Technical Committee. Engines which have been sealed by State Technical Representative are not subject to further inspection.

All cars are subject to general measurement at **any** time by the State Technical Rep, the Club Scrutineer, the State Technical Committee OR at the direction of the State Technical Representative, or the State Technical Committee.

Method of measuring wheelbase shall be: - With each front wheel pointing straight ahead, measure distance from front axle centre to rear axle centre on each side of vehicle. Add dimensions for left and right, divide by 2. Plus or minus 1% absolute.

Cars can be selected and ordered to the impoundment area for dismantling by the above mentioned Officials. The entrants of the cars must deliver them immediately upon request and supply the necessary workers and hand tools to accomplish dismantling.

Fig.1.

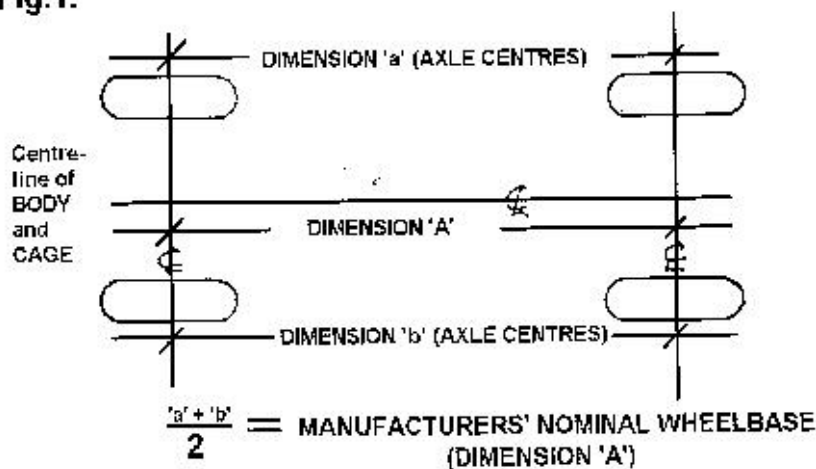

IMPOUND AREA

Only persons actually involved in dismantling the car will be allowed in the immediate area of a vehicle being checked. Persons associated with other cars being checked are to remain with their own car.

Any persons not having cars in the impoundment area, and gaining entry without authorization, will be ejected.

If there are no facilities for ready check of any parts of a vehicle, sealing of parts under question can be carried out and vehicle taken to a mutually agreed venue for examination at another time, but within fourteen (14) days.

Impounded cars will be stored at the owner's risk. Although every reasonable precaution will be taken no responsibility for fire, theft or damage will be assumed by the Q.S.C.A. and/or affiliated clubs.

PENALTIES: As per current Australian Speedway Racing Rules & Regulations

DRIVER/PASSENGER SAFETY:

All protective clothing and safety equipment must be used and/or worn in the approved and accepted manner.

All race wear/equipment may be inspected at each and any practice or race meeting.

For specific race wear approvals refer to current Australian Speedway Racing Rules & Regulations.

SEAT BELTS:

Five or Six point restraints are mandatory. Seat belts to be no older than 5 years from date of manufacture.

An approved type racing harness must be fitted, using a minimum of four major belts and four mounting points plus one or two anti-submarine/crotch straps. Anchor bolts to be 10mm STEEL min.

Only belts with over centre lever lock buckle to be used.

Rotary Cam units are designed for asphalt or concrete tracks only, do not use for Dirt or Off Road. (Reference - M&R Driver Restraint System Proper Usage Instructions)

INSTALLATION OF DRIVER/PASSENGER RESTRAINT SYSTEMS: Fig. 3

- In order for the driver/passenger restraint system to be fully effective, considerable thought must be given to the location of mounting points and to proper installation.

- With the seat, roll cage and seat belt anchors all part of the same structure; deformation of the remainder of the car does not put driver/passenger at serious risk.
- The mounting points must be solid and should remain so even if the vehicle is deformed due to an accident. The mounting points should also not put undue strain or twist on the seat belt system hardware.
- The lap belt should be positioned so it rides across the solid pelvic area and not the soft stomach area or down on the thighs. The shock absorbing ability of the pelvic area and its ability to protect internal organs make it the preferred location for the lap belt.
- The shoulder harness should be mounted to prevent drivers'/passengers' shoulders from moving forward (upwards if semi-reclining), out of the seat, in the event of a rollover. The required minimum 51 mm (2") from the top of the driver's helmet to the HEAD PLATE does not leave much leeway for the shoulder harness to prevent the helmet from striking the head plate or bar work in the event of a rollover. The shoulder harness is a major means of preventing injury in such an incident.

Anti-submarine straps serve two purposes.

1. To secure the lap strap down across the driver's/passenger's hips, so in the event of an accident, it is not pulled up across the stomach by the shoulder straps.

2. To prevent the driver/passenger from sliding forward and out of the harness. When the driver/passenger is seated in an upright position, as in most sedans, a five-point system (a single anti-submarine or crotch strap) is considered adequate. For extra assurance a double strap anti-submarine belt can be used.

- When the driver/passenger is seated in a semi-reclining position, a six-point system (two anti-submarine or crotch straps) is preferable. Most drivers/passengers find the two anti-sub straps system more comfortable.
- Typically, the anti-submarine straps are mounted much too far forward of the seat. This practice could cause unnecessary injury as the body can slide partially out of the seat before being restrained when the strap contacts the groin. It is much more practical to cut a slot in the seat bottom so the anti-submarine strap can be anchored in line with the chest.

Because of the differences (often vast) in competition vehicles, a "standard" method of mounting is impractical. Good judgment and common sense in inspecting restraint system mounts is needed.

Safety equipment is often neglected in favour of performance equipment, but its proper operation when the need arises is essential to survival.

- Shoulder belts to have separate anchor points/adjusters.
- Seat back support/shoulder belt mounting bar - 38 x 3mm ERW Minimum.

- Seat belt mounting brackets (anchor points) must be on roll cage and sub frame or substantial bar work (e.g. 38 x 3mm ERW) not on sheet metal.

ADJUSTMENT OF DRIVER/PASSENGER RESTRAINTS

- With the driver/passenger fully kitted out in "Long Johns" and driving suit, check that, with the driver/passenger seated, belt slots in the seat line up with natural line of the belt from anchor to buckle when just the lap belt is tensioned.
- Ensure that the lap adjusters do not foul the seat and that they are readily accessible. Some belts adjust by pressure downwards others by pull up. Check that the driver/passenger can manipulate belt adjusters with gloves ON. Check also that anchor hardware is aligned and that it is not possible to have a hitch in the anchor area without detection (sudden release of the belts to 50mm slack can put the driver/passenger off-line). Now check if the belt is holding the seat or the driver/passenger, it should be the latter.
- Adjust the anti-submarine strap/s to ensure that the buckle is held flat and close to the body over the pelvis.
- When satisfied that the lap belt is OK, put on the helmet and check just how far the helmet (with visor) can reach, head plate clearance, window net etc...
- Slacken the seat belt, engage the shoulder belts into the buckle and tension the seat belts again checking position of buckle and adjusters. Tension each shoulder belt, checking that the adjustment range is suitable to the driver/passenger, that the belts and hardware don't foul the seat and that the natural line of the belts holds the driver/passenger as with the lap belts. Note also any change in the buckle location and lay. If there is too much variation with buckle it would appear that lap anchors are not in optimum position.
- Before driver/passenger releases the buckle he/she should slacken shoulder belts with the adjusters, keeping the area of the adjuster supple, accessible for cleaning and making entry to the car a simple routine.

Note - While lining up for restarts, it becomes a simple exercise to tug the adjusters to snug up the belts and stay in control of the car.

Fig 3

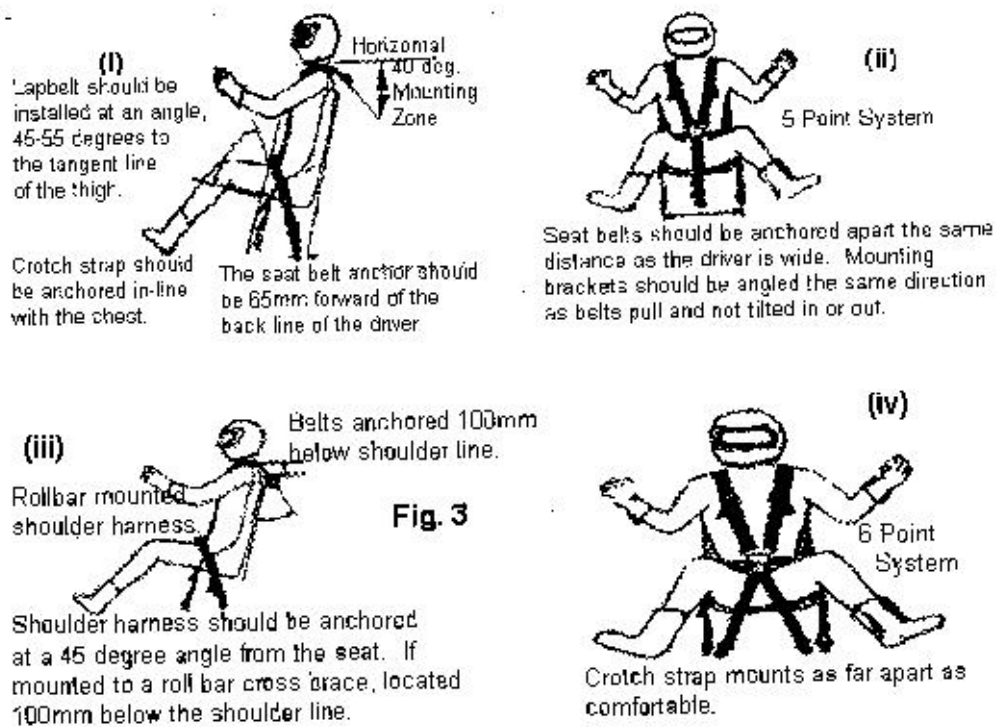

WINDOW NET is MANDATORY

Window Net to be of minimum 19mm (3/4") woven webbing with 75mm max. hole size. Preferably 50mm hole size. Minimum coverage to 407mm x 483mm.

Window net to be mounted by one of the three following recommended methods.

1. A minimum 6mm metal rod on top or bottom with a seat belt clamp for quick release either top or bottom.
2. A minimum 6mm metal rod on top or bottom with a sprung rod quick release either at top or bottom.
3. Both the top and bottom rods may be of quick release nature.
4. Window Net must be able to be released by driver/passenger whilst restrained by race harness.

**WINDOW NET RECOMMENDED
INSTALLATION**

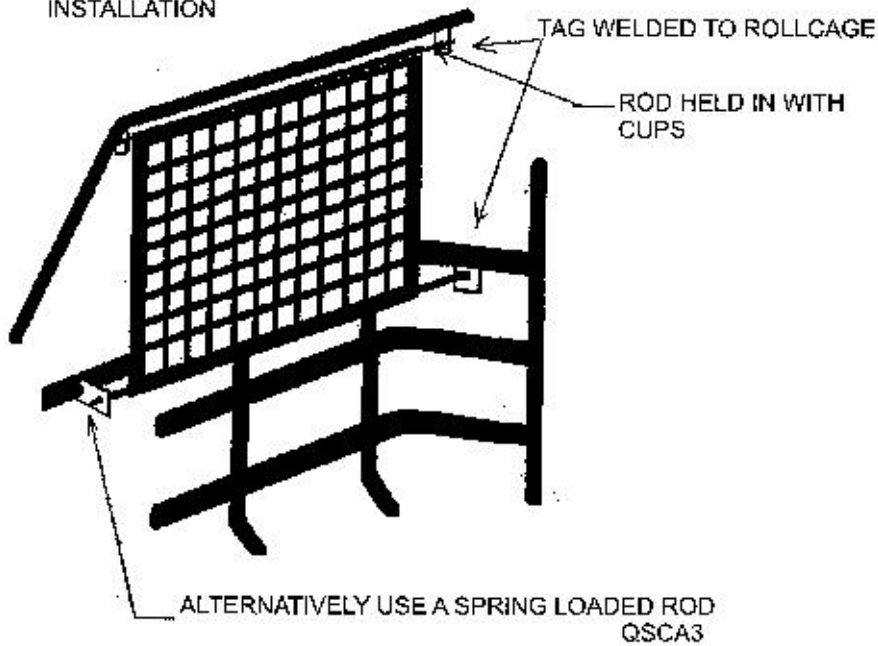

**WINDOW NET RECOMMENDED
INSTALLATION**

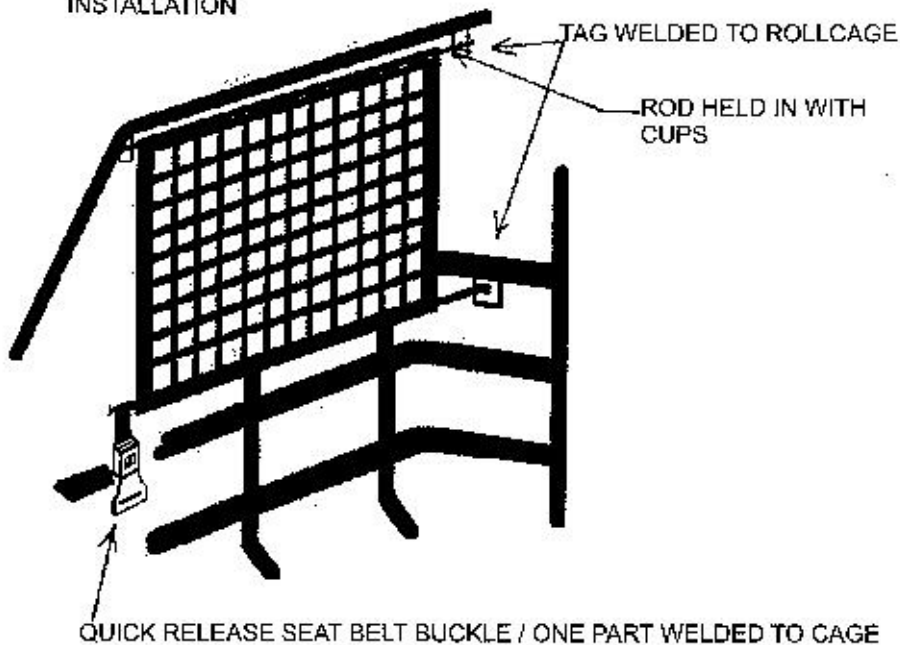

PADDING:

The driver/passenger must be protected, in the racecar, from all sharp edges and projections or bar work that could cause injury in an accident. Padding that is required on bar work, will be if the helmet of the driver/passenger is within 75mm of bar work while fully restrained in the race seat. Please bear in mind the non-use of flammable padding is required.

Exception: If seat has head restraint fitted.

FIRE EXTINGUISHER:

On board Extinguisher allowed. It must be securely mounted and be of the correct type for the fuel being used and to be within service date.

BODY

TYPE OF SEDANS THAT CAN BE USED

MONO-CONSTRUCTED vehicles only of sedan, coupe or hatchback style, seating a minimum of four adults and catalogued for general sale in Australia.

No special import vehicles allowed. Manufacturer's specifications will be used to determine all measurements.

The following vehicle types are NOT PERMITTED TO BE USED:- Station Sedans, Panel Vans, Utilities, Convertibles, 4 Wheel Drive Vehicles, 4 wheel steer vehicles and All wheel drive vehicles.

All vehicles to be kept in good repair so as a better image can be projected to the paying public and to prospective sponsors.

PARTS TO BE REMOVED FROM BODY

1. All mirrors, brittle plastic die cast or metal strip grills, door handles and ornamentation mouldings and also all flammable insulation material.
2. Bull bars and tow-bars are to be removed. Original fuel tank to be removed.
3. Original bench or sprung bucket seats to be removed.

MODIFICATIONS TO BODY

1. Inner panels in cabin area may have minor modifications to allow roll cage to be fitted.
2. Original dash panel may be removed and replaced.
3. Original front firewall to be in use and to be fully sealed from cabin area.
4. A rear metal firewall must be fitted to isolate driver/passenger from boot area. All cars must have manufacturer's rear parcel tray in place.

If a vehicle is used where a firewall was not fitted as standard the fuel tank must be isolated from driver/passenger using metal of 1.0mm minimum and 1.6mm maximum.

5. Wheel arches may be cut out to allow clearance for tyres to a maximum 100mm.
6. Body metal size 1.6mm maximum.

7. Race car is to use an original, metal body with the suspension mounting points in original position and being used. All panels are to be securely attached to body. E.g. Rivets, Bolts or Welded.

8. Bonnet to be securely attached to body at five (5) points (i.e. one in each corner and one in centre of front of bonnet panel) and Boot to be securely attached to body at four points (i.e. one in each corner). Bonnet and Boot pins to be a minimum of 12mm Rod with locking pins of 3mm minimum.

Strips across rear corner of bonnet and front corners of boot lid permitted. These are to be 50mm x 1.6mm body metal plus three/two pins. If bonnet and/or boot retain hinges, no skeletonising of hinge area is allowed plus must be welded to panel. A minimum of 2 x 12mm pins to secure panels. NO BONNET SCOOPS PERMITTED. If skeletonised bonnet or fibreglass bonnets are used, 5 pins must be used (one in each corner area and one in the centre at front), with heavy-duty large reinforcing washers (30mm OD min).

9. If the original grille can not be used, a substitute grille is to be made retaining the original appearance as close as possible.

10. Headlight and Tail light apertures to be covered, with maximum 1.6mm material.

11. Fibreglass or other approved material panels can be used as a replacement for any or all-removable steel panels. To keep the cars in a presentable condition, removable fibreglass panels may still be used over non removable original steel panels. NO OTHER DOUBLE PANELLING PERMITTED.

12. Fibreglass or other approved material panels to be of original shape and mounted securely in the original position. Panels that may be replaced with fibreglass or other approved materials are front guards, bonnet, door skins, boot lid and rear quarter panels. The steel roof must be retained but may be covered with a fibreglass or other approved material skin. The optional removal of metal rear quarter panels in the boot area is approved, to be cut vertically at the rear window base line. Rear Silhouette to be maintained with plastic OEM bumper over the top of pipe bumper bar work.

13. No self-tapping devices to be used at all.

14. Front and rear under bumper stone trays must be original in shape or may be replaced by a pre-molded unit.

15. Boot floor may be removed up to the centre line of rear axle or no closer than 50mm to rear of suspension mounting points.

16. The rear boot panel may be replaced with plastic, fibreglass, metal or other approved material.

IDENTIFICATION NUMBERS & REGISTRATION DECAL

All vehicles must carry the correct allocated identification number. Number to be displayed on each side of car and on roof.

Roof number plate must be 300 x 300mm absolute x 1.6mm MIN. mounted vertically and to be angled from left front to right rear. Colour must be white numbers on black background. Numbers to be in block font. For manual lap scoring purposes roof numbers will continue to be required to be used even with the use of Transponders.

Numbers and Club prefix to be on each side of car, in contrasting colours. Numbers to be in the correct orientation.

Driver's name must be written on right hand side of roof above door or on visor strip.

For the benefit of forming up at race re-starts the club prefix and registered number must be placed on the rear of the car adjacent to the right hand side tail light aperture.

Q.S.C.A. INC. REGISTRATION DECAL TO BE PLACED ON RIGHT HAND SIDE OF CAR.

TRANSPONDER MOUNTING

Transponders when required, will be mounted in all cars in the front radiator support panel area in a position to obtain a clear view of the loop. Transponders will be mounted as low to the ground as possible, no higher than 600mm from the track surface.

ONE WAY COMMUNICATORS

All drivers will use the One Way Communication system whilst competing for purposes of the communication from the Race Official. One Way Communicator mounting box may be mounted to the roll cage by way of zip ties.

COMMUNICATION TO & FROM RACE CARS

The only communication is by race officials on One Way Communication.

ROLL CAGE SPECIFICATIONS

1. The roll cage is to prevent the collapse of the cabin area under impact.
2. Q.S.C.A. accepted sedans must build the N.A.S.C.A.R. type roll cage.
3. All bars will be one piece not extended by butt-welding. All bends to be made by using a pipe bender with the correct size former for the pipe being used.
4. Galvanised tubing or Alloy based materials not permitted. Water pipe fittings or malleable fittings not permitted.
5. All bars constituting the roll cage to be fully welded.
6. All bars to be subject to Sonic Test. Sonic Test at not less than 2.70mm absolute.
7. Roll cages built using other than fusion welding techniques will not be accepted.

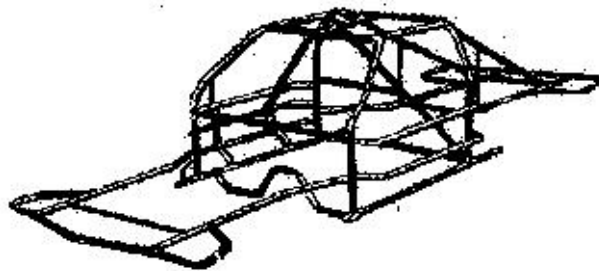

ROLL CAGE CONSTRUCTION

1. No drilling of main roll cage permitted.
2. Accepted roll cage design must be totally inside car body and follow roofline.
3. Roll cage must extend from behind driver's/passenger's seat forward to the windscreen area and incorporate protection for the driver's feet.
4. Roll cage legs shall be welded to a sub frame of tubular or angle section running fore and aft and welded to sill panel or bolted to floor pan by four 12mm bolts. Plates Max 100 x 100 x 3.0mm under floor to stop bolts pulling through floor.

Roll Cage Sub frame sizes must be one of the following options:

- (a) C.H.S. 38 x 3mm ERW or 32NB Med (42.4mm O.D.) or
- (b) R.H.S. 50 x 25 x 3mm or 40 x 40 x 3.0mm or 50 x 50 x 3mm or
- (c) ANGLE 50 x 50 x 5mm

5. Steering column must be securely mounted to the lower windscreen dash bar.
6. Quarter window bar required if rake of windscreen is less than 45 degrees to the doorsills. This bar to be minimum of 20NB Med. C.H.S. Quarter window bar to be mounted from the front roll cage leg at half windscreen height to the top NASCAR door bar in a vertical position.

BARS REQUIRED - All materials quoted are absolute, exceptions are where stated as minimum or maximum sizes.

1. Main roll cage hoop across body to be 38 x 3mm OD ERW or 32NB Med (42.4mm OD) minimum or 50 x 3mm C.H.S. OD maximum.
2. Full crucifix to be fitted 25NB Med. or 32NB Med C.H.S. or 38 x 3mm ERW. Main bar of crucifix must be one piece, top right to bottom left.
3. Front roll cage legs and roof bars 38 x 3mm ERW or 32NB Med. C.H.S. or 50 x 3mm C.H.S. OD maximum.
4. Top and Lower windscreen bar/dash bar 38 x 3mm ERW or 32NB Med. C.H.S. or 50 x 3mm C.H.S. OD maximum
5. Bar from lower windscreen bar to scatter shield **or** spreader bar 25NB Med. C.H.S. minimum or 50 x 3mm C.H.S. OD maximum.
6. N.A.S.C.A.R -BARS - Drivers and Passenger.
Three horizontal bars between front and rear roll cage legs **evenly** spaced between top of door panel and sill sub frame and curved out towards the door skin on both ends. Minimum of two sets of vertical bars between sill sub frame and top door bar **evenly** spaced between front and rear roll cage legs. 38 x 3mm ERW or 32NB Med. C.H.S.
Top door bar to be within 50mm of top of door.
7. A deflector plate, 3mm steel or 5mm Aluminum to be fitted on driver's side forward of the first uprights to the front roll cage leg. On the passenger side a rear deflector plate to be fitted between main roll cage hoop and the second set of uprights. Minimum of one third of the door opening to be covered from top door bar to roll cage sub frame.
8. Centre windscreen bar - 25NB Med C.H.S. Minimum or 50 x 3mm C.H.S. OD maximum.
9. Centre roof bar - 25NB Med C.H.S. Minimum or 50 x 3mm C.H.S. OD maximum.
10. Minimum of two spreader bars mounted at roll cage legs. 38 x 3mm ERW or 32NB Med. C.H.S. or 40 x 40 x 3mm RHS Minimum.
Option – Front spreader bar may be mounted within 200mm of roll cage front leg.
11. Roof Plate - 3mm Steel or 5mm Aluminium plate must be full width of roll cage and to extend from main roll cage hoop to top windscreen bar. This plate to be securely welded or bolted to all roof bars.

A 25 x 3 FMS strip to be welded to main hoop, top windscreen bar, centre roof bar and side roof bar over both driver and passenger or 10 tags 50 x 50 x 3 FMS acceptable. 10 x 8mm High Tensile bolts to be used over both driver and passenger. i.e. 3 each side, 2 front and 2 rear.

12. The seat back support/shoulder belt mounting bar to be 38 x 3 ERW or 32NB Med. C.H.S. The bar providing the anchor points for the shoulder belts is to be positioned so that the belts are anchored a maximum of 300mm from the point at which the shoulder belt comes through the back of the seat and a minimum 100mm below the shoulder line.
13. Roll cage rear brace bars - Two bars to run from outside top of main roll cage hoop to the rear chassis bars inside rear boot panel. Bars may be in crucifix form. 38 x 3mm ERW or 32NB Med. C.H.S.
14. Rear chassis bars to follow contour of floor from foot of main roll cage hoop to attach to rear bumper or be a maximum of 300mm from foot of main hoop. Material to be 38 x 3 ERW or 32NB Med C.H.S. or 40 x 40 x 3 R.H.S. A rear radiator may be mounted to these bars.
15. Windscreen Mesh – A mesh screen to be supported and securely fastened to roll cage at a minimum of 5 points and cover full windscreen area.
Mesh size – minimum 25 x 25 x 2mm up to a maximum of 50 x 50 x 3mm minimum gauge mesh. HIGHLY RECOMMENDED - Screen to be fixed in such a manner to enable quick removal. i.e. pinned, bolted, or clamped
16. Foot Protection - Plate or bar work to extend forward of roll cage to afford protection to pedal box area. Can be either 38 x 3mm ERW or 32NB Med C.H.S. or 50 x 3mm C.H.S. OD maximum and/or 3mm plate. These bars not to extend past pedal box.
17. Gussets may be required. (Subject to State Technical Rep inspection).
18. A scatter shield of 3mm minimum steel must be fitted to extend and cover upper 180 deg. of the clutch housing to protect the driver's or passenger's limbs in the event of clutch or torque converter shattering. Minimum size to be 3mm x 250mm wide.
19. Fuel tank protection bar must be fitted, and be made from roll cage material, 38mm x 3mm CHS. This bar to be mounted between rear panel and no closer than 25mm to fuel tank. This bar must also be 50mm wider than both sides of the tank and a minimum height of 150mm or 75% of the height of the tank, whichever is the highest measurement. The protection bar is to be braced forward by 20NB Med C.H.S or 25 x 25mm x 3mm RHS Minimum.

FRONT ELEVATION

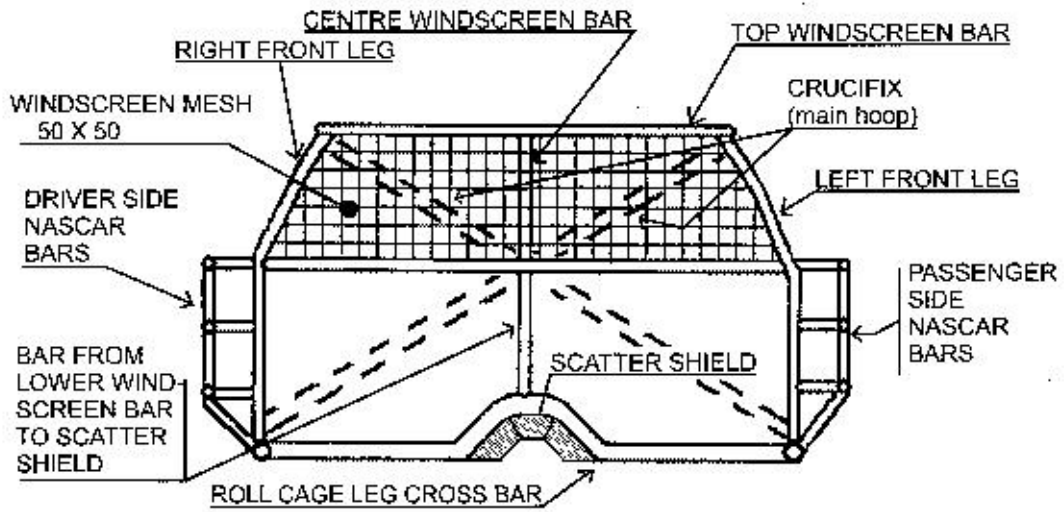

REAR ELEVATION

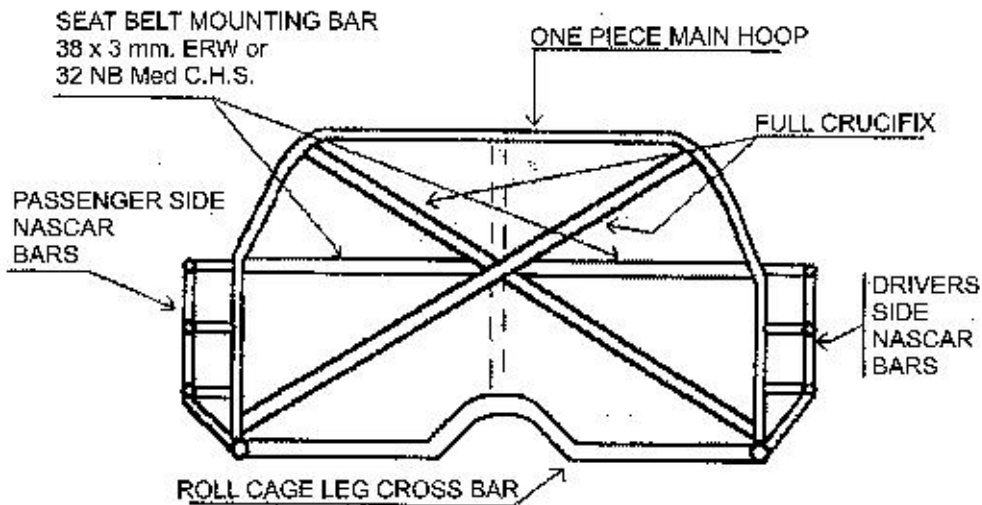

BUMPER BARS:

1. Front and rear bumper bar to be 38 x 3 mm ERW or 32NB Med. C.H.S. Corners and ends of front and rear bumpers to be radius formed 100mm minimum. A maximum of four (4) mounting points on front bumper. Returns of bumpers to be within 50mm of the body. Anti-hookup bars from returns of front and rear bumpers to be extended to chassis rails.
2. Bumper bars must follow original contour of body and be a maximum of 50 mm from inside edge at bumper and body.
3. Rear only: Returns of rear bumper may be extended as a skid rail within 50mm of the outside of body between bumper and wheel arch, and then extend inward to the "chassis rails". Maximum of six (6) mounting points – as per diagram. Option – 2 x 20NB Med brace bars welded to rear chassis rail spreader bar in boot compartment (not welded to rear bumper bar). As per diagram.
4. 25 x 25 x 3mm RHS or 20NB Med. C.H.S. braces may be fitted to bumper corners but not constitute mounting points.
5. Rear override bar: A free standing override bar may be used - constructed of 20NB Med, C.H.S. Maximum, it shall be no wider than the boot panel and shall be mounted centrally on top of **or** below the bumper bar at no more than four (4) points, be vertical and be maximum 100 mm high. Height measured from override OD to bumper OD.
6. Front override bar: A free standing override bar may be used - constructed of 20NB C.H.S. Med maximum 600 mm long x 150 mm High and mounted centrally on top of bumper at three (3) points only.
7. Rear bumper may be mounted to rear chassis bars in boot and extend out to maximum 50 mm from inside edge of bumper.
8. Front bumper must be mounted to two (2) chassis rail bars that mount to sub frames by four (4) bolts or welded. Bolt holes to be sleeved through sub frame - 10 mm bolts only (as per diagram) or may be mounted through centre of rails and extend to roll cage either to Roll cage legs or sub frame cross brace at floor level and mounted back to roll cage sub frame.
Material to be 38 x 3 ERW minimum or 32NB Med C.H.S. or 40 x 40 x 3 R.H.S. or 50 x 3mm C.H.S. OD maximum.
9. Plastic bumper bar must be retained. Plastic bumper bar to mounted securely to pipe bumper bar. All external bumper barwork to be covered with plastic bumpers.
10. **NO OTHER REINFORCING ALLOWED.**

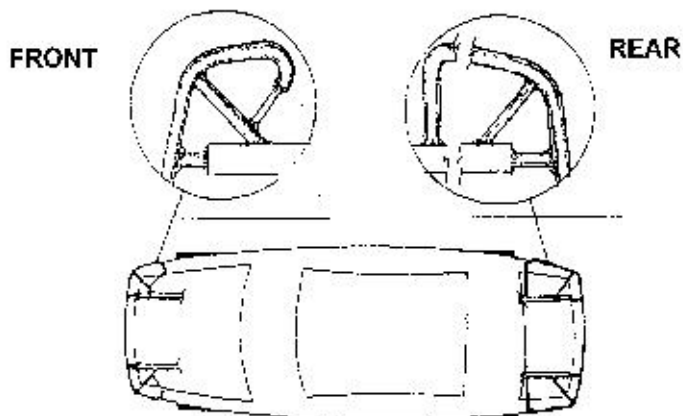

VEHICLE RETRIEVAL METHOD

1. A lifting point is to be fitted at front and rear of car to enable quick efficient removal from the race track when needed.
2. Suggestion – seat belt webbing to be wrapped around pipe bumper and be accessible through plastic bumper bar.
3. An override bar is acceptable as a lifting point if it is accessible without removing any panels.

OPTIONAL BAR WORK

The following bar work is an option, drivers may choose not to install the optional extra bar work.

1. Rear Door Panel Protection Bars - For safety and panel protection, maximum of three bars 38 x 3mm ERW or 32NB Med C.H.S. May be extended from main roll cage hoop to rear of rear door or front of rear inner guard. A strip of 50 x 3mm FMS may be used to attach bars to bodywork.
2. Strut Tower braces may be fitted, maximum 25 x 25 x 3mm RHS or 20NB Med. C.H.S. welded to lower windscreen bar, either at roll cage legs or at centre windscreen bar and to be gusseted.

3. Excepting for the bumper and bumper support bars, all bar work outside the sub frame skirts forward of the firewall, i.e. under front guards, shall be a maximum dimension of 20NB Med CHS or 25 x 25 x 3mm RHS. This bar work may attach to bumper supports by using one 25 x 25 x 3mm RHS on each side of the car.
4. The bar work between the chassis rails from within the engine bay to the boot compartment is free using up to the maximum material size as per the specification.
5. Front under bonnet area - to be no more than four (4) uprights across the front and no more than ten (10) brace bars in engine bay. Rear boot area - to be no more than five (5) uprights across the rear of car and no more than ten (10) brace bars in the boot area. This bar work is to be a maximum of 25 x 25 x 3mm RHS or 20NB Med CHS.
6. Frame for Grill may be fabricated, using 20NB Med C.H.S. or 25 x 25 x 3mm RHS frame, filled with a sheeting maximum of 1.6mm material. Grille may be a section of mesh no greater than 25 x 25 x 3.15mm to retain the original appearance.
7. Inner guards may be removed from 50mm forward of any suspension points e.g. strut towers.
8. Original front sub frames must remain in place, except that, the sections forward of the leading edge of both front tyres may be removed, unless they constitute suspension mounting points: e.g. Forward caster arm (radius rod) mounting on McPherson strut.
9. Front wheel drive cars with transverse engine may modify the engine cradle assembly to strengthen the engine mount. 20NB Med C.H.S. or 25 x 25 x 3mm RHS Maximum to be used.
10. Mild steel rubbing strip between wheel arches to be 25 x 25 x 3mm MS RHS or alternately, nylon (urethane, nolathane) 50 x 12mm thick. Be securely mounted against body at a minimum of four points. Bolts must be minimum of 8mm coach head (cuphead) bolts and be bolted horizontally to bar work. Bolts at each end must be no more than 50mm from the end of rub rail. Inner mounting bar, minimum 25x25x3mm to be returned to chassis or roll cage at each end. Rubbing rail ends to be closed and taper to 45 degrees as not to become a 'spear'. Rub strips not to be used on quarter panel behind rear wheel.

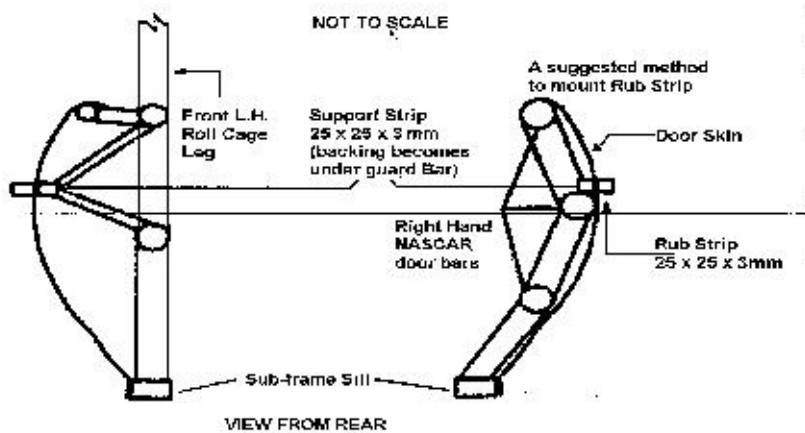
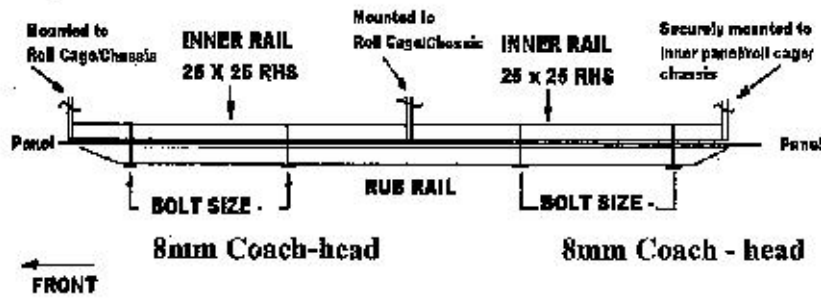

FRONT/REAR HUBS, AXLES AND TAIL SHAFT

1. Rear Axle Bearing Retaining Rings: If using a rear axle assembly not fitted with floating axles, a new retaining ring must be fitted at replacement of bearing or axle. It must be an interference fit with the axle. When in place the retaining ring is to be **tack** welded to the axle using small diameter low hydrogen rods or Mig Welded on low amperage. Failure to observe these procedures will incur a penalty especially if an axle is dislodged.
2. Tail Shaft Straps. Tail shaft(s) must be fitted with 360 deg. hoops (Minimum 25 x 3mm to 40 x 5mm FMS Maximum) or chains or wire rope cable (MIN. 6mm) at front and rear to prevent the tail shaft dropping out in the event of a shaft or universal joint breakage. Straps must be securely mounted approximately 150 mm from the universal joint and incorporate full loop through floor pan.

REPLACEMENT FUEL TANK AND FUEL SYSTEM

1. Original type car fuel tank must be removed.
2. A fabricated steel tank, 50 litres Max, using Min1mm gauge material. All joints to be welded or lapped and brazed.
3. A fabricated aluminum tank 50 litres Max, using Min 3mm gauge material. Tig welding recommended.
4. A certified and recognized Boat Fuel Tank or Fuel Cell. NO OTHER PLASTIC TANKS.
5. All fuel tanks must have a positive seal fuel cap.
6. A breather hose to be fitted to tank and must cover all sides of tank i.e. 6 sides, to alleviate spillage in a rollover **or**
A recognized Metal non-return valve can be used in a short breather hose to avoid spillage. Eg Sigma / Toyota metal brake booster valve.
7. Pressurized fuel tanks not permitted.
8. Fuel tank to be securely mounted between rear chassis rails in a suitable cradle in the boot area.
Fuel tank to be secured by the use of straps attached to the cradle.
Fuel tank not to protrude under bottom of original sub frame.

For ventilation of fumes the area where original fuel tank was removed to be left open. In the type of cars where the original fuel tank was under the floor, the area that was covered by this to be removed from the boot floor.
Minimum size hole to be 300 x 300mm.
9. Fuel tank to be no closer than 150mm from rear panel.

FUEL LINES AND FITTINGS

1. Copper, Neoprene, "Black Fuel Line" may be used. If copper pipe is used a minimum length of 75mm of flexible hose to be used at fuel tank and fuel pump. The correct fittings and screw type clamps to be used on all fuel pipes and hoses and be securely attached on top of the floor. Where fuel lines go through front and rear firewalls, lines to be suitably grommetted.
2. The fuel line must be fitted with a quick action non-leak fuel tap, in working order, securely mounted within easy access by the hand of driver, passenger and crash crew and method of operation clearly marked. Alternatively an electronic fuel lock may be used.

3. E.F.I CARS are NOT permitted to have a fuel tap in the Cabin area. Fuel lines to be one piece in cabin area.
4. Glass bowl fuel filters **NOT** to be used.

BRAKES

1. Effective foot operated brakes on **ALL FOUR** wheels.
2. Adjustable brake bias systems **NOT PERMITTED**.
3. Any car model produced where ABS brake system is available then that option may be used.
4. All brake components used are to be O.E.M. or O.E.M. replacement parts only and be in the original position with no additional components being used.
5. Brake boosters optional.
6. **Super Street Sedans only:** Rear brakes may be altered to disc brake system.

PEDAL CLUSTER

1. The use of an aftermarket pedal cluster is **NOT PERMITTED** - E.g Willwood
2. All pedals must be mounted in the original position with all OEM components being used.

COOLING SYSTEM

1. Radiator can be mounted in front of car in original position and/or in rear of cabin area.
2. Radiators may be mounted as low as possible in the rear firewall.
3. The upper half of the window **MUST NOT** be obscured by the rear radiator.
4. All radiator hoses must be fabric reinforced material, plain molded hoses not permitted. Cabin mounted radiators must have **BOTH** tanks and cap covered to protect driver/passenger in the event of the cap or tank blowing.
5. All hoses must be as short as possible and fitted to radiator from rear side.

6. All pipes in cabin area to be steel, aluminum or copper tubing securely mounted to roll cage and body.
7. All pipes to have no joints in close proximity to driver and passenger and must be suitably isolated and lagged - in cabin area.
8. Auxiliary fans to be shrouded.
9. A manual pressure relief tap and hose to be fitted to release pressure.
Alternatively a Lever-Vent Cap to be used. Push button type caps not permitted. Where an ordinary radiator cap is used, it must be wired or screwed to prevent removal when hot.
10. Radiator Shrouds and Air Deflectors. Rear mounted radiators may have air deflector strips fitted to front of radiator and be mounted securely to back of roll cage. Sides of deflector to be no higher than half the height of the rear window and no longer than 600mm forward of the radiator.
11. Radiator irrigation systems are not allowed. The use of expansion filler tanks is limited, with discretion showed by the Scrutineer.
12. Electronic Water pumps are allowed. Original OEM water pump to be in place.

BATTERY AND ELECTRICAL SYSTEM

1. Battery to be securely mounted in a box or metal frame secured to roll cage or bar work. It is recommended that rubber covering be placed over the battery and the exposed metal of the cable terminals to reduce acid spillage and to reduce chance of arcing if metal contacts battery in any incident. Plastic clamps not permitted. Steel box thickness to be no greater than 5 mm absolute and relative to the battery being used. Cabin mounted battery must be fully enclosed in a box.
2. Rubber covering must be placed over the top of battery to prevent arcing of terminals.
3. Rubber grommets must be fitted to cables and wirings when passing through any panels.
4. All wiring must be mounted clear of fuel lines. No switches to be mounted through floor.
5. An engine 'KILL' switch or battery isolator switch must be fitted in the centre of the "cowl panel". Method of operation suitably marked with a contrasting colour.
6. At the commencement of a meeting, car must be capable of starting with starter motor.
7. Maximum of 1 only battery allowed – no greater than N70ZZ.

SEATS - DRIVER AND PASSENGER SAFETY

1. A high back one piece steel (1.6mm minimum) aluminum (3mm minimum) or fibreglass bucket type seat must be used, as approved by the QSCA Inc. Approved proprietary line competition seats and mounts permitted. E.g. Kirkey/Butler/Genesis
2. Lateral (sideways) support must be given to hips and above waist.
3. Concave seat to support back to a minimum of TOP of shoulder height and width.
4. Head rest to be 150mm wide at point of contact with helmet and padded up to 50mm thick Max. resilient material.
5. Front of seat under legs to be raised and rolled.
6. Cut-outs for belts to be suitably grommetted.
7. All seats must be fully padded and covered 50mm Maximum. Dominator Seats are deemed to be covered seats and do not require any further covering.
8. Spring upholstered or magnesium alloy seats not permitted.
9. Seat base to be mounted by four 8mm bolts with large washers to minimum 25 x 25 x 3mm RHS or 20NB Med C.H.S. frame, attached securely to roll cage.
10. Seat back to be bolted (with minimum two 8mm bolts) to a brace attached to roll cage approx. 75mm below shoulder height.

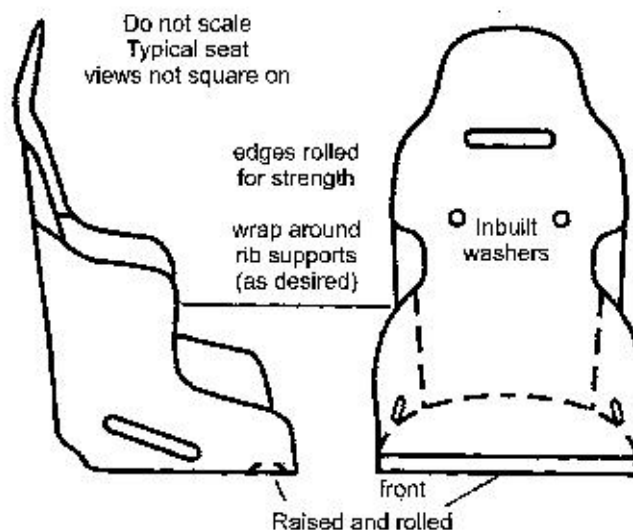

11. On fibreglass seats a rear strengthening support from bottom of seat to head rest mount 25 x 25 x 3mm RHS. MIN. or 50 x 3mm FMS. Rear brace behind seat to be wrapped around back of seat 40 x 3mm FMS at top mounting point. With the use of The AUSSIE CONCORD seats this bracing is optional.
12. Rear of seat face to be no further back than 125mm from centre pillar, to be measured at door height for 4 door cars. For 2 door cars to be measured level with rear of door pillar.
13. Drivers seat may be made to be adjustable. Check with State Technical Rep. for approval of installation method prior to installing adjustable seat.

STREET

SEDAN

SPECIFICATIONS

THE ONLY MODIFICATIONS PERMITTED IN STREET SEDANS ARE THOSE LISTED WITHIN THESE SPECIFICATIONS. IF IT IS NOT LISTED FOR MODIFICATION IT REMAINS O.E.M. TO THE MANUFACTURERS SPECIFICATIONS

STREET SEDAN

The intention of this class is to be as close to standard as possible. Various restrictions apply to this class. **SPECIFICATIONS ARE AS PER MANUFACTURER'S SPECIFICATIONS.**

Be careful in selecting a vehicle, the rules will NOT be altered to suit your choice. There is definitely no intention to alter specifications to permit the 'hotting' up of engines, fitting of larger wheels and tyres or bar work for barging. Alterations to specifications for vehicles would be for SAFETY reasons ONLY.

ENGINE

1. Engine must either match model car being used or be an earlier model engine for the model car. If an earlier model engine is being used it must be positioned in the engine bay with the rear face of the block in the same position as the original engine for that model.
The parent manufacturer's markings and numbers must remain on engine blocks. Complete engine to be visibly standard. Maximum 6 cylinder, normally aspirated engines only. No turbo charged, super charged or rotary engines permitted.
2. Engine Restraint must be fitted if the engine mount is not solid. If resilient engine mounting is used a 6mm wire cable or 6mm chain restraint must be used.
3. Crankshaft stroke not to be increased or decreased relative to the block being used. Crankshaft may be modified to allow better lubrication.
4. Con-Rods and Pistons to be original design with the conrods to be O.E.M. for the block being used and MUST be Block – Conrod – Crankshaft combination as per manufactures specifications. E.g. A 4.1 Ford block must have 4.1 Crankshaft and Conrods.
5. Camshaft and Cam Followers. Camshaft to be open. Hydraulic Lifters remain hydraulic.
6. Oil System. Original type oil pump to be fitted. Internal modifications are permitted. Remote oil coolers not permitted. One only oil filter may be used in the original position or you may use a remote equivalent to the filter as fitted to the engine originally. Hydraulic hose to be a maximum 1 metre in length and maximum 16mm diameter. Filter must remain in engine bay compartment. Sumps may be baffled but not extended. Oil pump adjustable relief valve permitted. Tappet covers may be vented but not connected. Oil catch cans permitted.
7. Engine Measurements. The standard size engine is allowed a maximum overbore of 0.060".

8. Harmonic Balancer and Flywheel. Harmonic balancer used must be OEM. No modifications allowed.
9. **DISTRIBUTORS when used: Standard ignition system** to be retained for make and model engine being used.
10. Double row timing chains and multi-key timing gears are permitted to be used only if all engine components remain and are operational. All O.E.M. engine components **MUST** be operational.
11. Engines may be sealed, they must be fully measured prior to assembly by the current State Technical Representative. Engines sealed by current State Technical Representative will not be required to be pulled down for checking at the completion of a meeting.

Engines will be inspected on the basis that all parts used in/on all engines must comply with the specifications/dimensions specified in the original (O.E.M.) manual produced by the manufacturer for the standard engine; with the exception of the listed permitted modifications. The owner/driver is responsible to prove the above and produce information when necessary to validate the claim.

Refer, Australian Standards "AS 4182-1994 Code of Practice for Engine Reconditioning Standards". **ENGINE BALANCING:** The balancing of any engine componentry or removal of any balance shaft in this class is **STRICTLY PROHIBITED**. The only tolerances allowed are the drill holes in the crankshaft as done by the manufacturer (O.E.M.). The Conrods cannot have any metal removed or polished. The pistons cannot be machined or lightened.

CYLINDER HEAD

For purposes of registration car, engine and cylinder head model must be stated.

1. Cylinder head to be of original material, type, make and configuration.
2. Cylinder heads to be from Parent Manufacture of make and type as fitted to engine.
3. Inlet and Exhaust valves to manufacturer's specifications for cylinder heads. (Normal tolerances for machining permitted.)
4. Standard type rocker arms and push rods must be used. All rocker arms to be O.E.M. for the Engine being used.
5. Valve Springs - The original configuration must be retained:
SINGLE REMAIN SINGLE.
6. Inlet and Exhaust Ports. Inlet and exhaust ports must remain standard: no change of size, design or polishing.

O.E.M. FUEL INJECTION

The following are specific items relating ONLY to models produced with OEM EFI/TIMED injection.

1. OEM fuel injectors are to be used. E.g. Bosch to remain Bosch
2. Fuel to be supplied from any commercial outlet through any multi volume network via bowser pump. To be a maximum Sg 0.780. (Sg to be measured at 15 degrees Celsius) No exotic or racing fuels or additives eg. ELF, VP etc
3.
 - a. Air cleaner and sensor to be free and remain in the engine bay.
 - b. All sensors being used must be in the original position, exception air cleaner to throttle body free.
4. Passenger car fuel pump only is permitted.
5. If a Fuel Pressure gauge is used it must be mounted in the boot area or in engine compartment.
6. Computer Control Units are not restricted. If OEM unit includes ignition, the modified or replacement CCU must also perform this function.
7. Size of throttle body; Throttle body to be OEM **type and size** for model engine being used and to be standard in INTERNAL and EXTERNAL appearance, any model car without cable throttle may be modified to fit linkages for the use of cable throttle and return springs.
8. Return springs must be fitted to each butterfly shaft (in built springs accepted), and one spring to accelerator pedal linkage.
9. Non-OEM Fuel Injection **NOT** permitted - forced induction NOT permitted.

CARBURETOR

1. Carburetor. A single carburetor as per manufacture of the make and model of engine being used (no sports models): XE Falcon can use 2 Barrel Weber 34 A.D.M. Carburetor, and to remain standard and retain all components. Jets may be changed for tuning. This includes the fitment of an adjustable main jet.
2. Original type fuel pump must be used.
3. Inlet Manifold. Manifold to match the engine and/or the model car being used. No modifications permitted to manifold: standard measurements and finish to be retained. NUMBERS TO REMAIN ON MANIFOLD.
4. Fuel to be supplied from any commercial outlet through any multi volume network via bowser pump. To be a maximum Sg 0.780. (Sg to be measured at 15 degrees Celsius) No exotic or racing fuels or additives eg. ELF, VP etc

5. Air Cleaner MUST BE USED (to suppress backfire).
6. Choke butterfly and shaft to be removed for safety. Holes in body to be plugged.
7. Two springs must be fitted at two separate points on throttle linkage, one at butterfly shaft and one to pedal linkage (cable).
8. Refer to carburetor listing on Page 34.

EXHAUST

1. The standard base model exhaust manifold must be retained. Extractors or aftermarket headers not permitted - Exception being that fuel injected VK Commodores is allowed to use the original header type 'extractors'. Exhaust to be securely attached to manifold and underbody of car.
2. Pipes must extend past driver and passenger seat and be directed away from fuel tank, tyres and other competitors.
3. Exhaust noise must be muffled to be within local Government authority requirements. To Max 95dba.
4. Muffler and Exhaust Pipe must be chained to body in two (2) places with minimum 6mm Chain.
5. Heat dispersant coatings on the outside of the exhaust manifold are acceptable but no coating allowed on the inside.

TRANSMISSION

1. The original parent manufacture gearbox for the engine being used must be fitted. Ratios may be changed but case not modified externally. Aftermarket bell housing may be used. Car fitted with automatic transmission must have standard converter fitted and be operational.
2. Clutch must be fitted and operational. Lightening of flywheel not permitted. Flywheel to be O.E.M. to engine being used. Pressure plate to be standard replacement to engine being used.

DIFFERENTIAL

1. The original type and model of differential housing must be retained.
2. Crown wheel and pinion may be changed provided no modification to housing to allow fitment.
3. Differentials may be locked.

4. Diffs may be changed but the width cannot be changed from original and must bolt up to the original mounting points.

SUSPENSION

1. All suspension components used must be OEM – NO MANUFACTURED PARTS OR MODIFIED PARTS PERMITTED UNLESS SPECIFIED. The original type suspension must be retained using ALL the original mounting points in the original position and to operate in the manner as specified by the manufacturer.
2. Only the front control arms, both upper and lower, or tie rod /ends can be modified a maximum of 25mm, + or -, to be measured centre of mounting bolts. Rear arms cannot be altered in length and will be measured from mounting bolts. Aftermarket bushes are permitted. Original cross member must be used to match the model car being used.
3. OEM suspension parts may be strengthened/reinforced
4. No additional components permitted: Stabiliser Bars, Shock Absorbers, and Panard Bars etc. Sway Bars where fitted may be disconnected or removed.
5. Both ends of the Panard Bar to be in the original mounting position where fitted as standard equipment. Watts link, where fitted, to be mounted in the original position and operate in the normal manner.
11. No adjustments can be carried out from the cabin or from the drivers seat or whilst on the dummy grid or the race track.
12. Shock absorbers with adjustors, that can be adjusted manually, or using any tools, whilst the shock absorber is mounted in position not be permitted.
13. Springs may be upgraded and adjustable.
9. Weight jacking systems incorporated into the spring mountings are permitted but are not to be adjustable whilst car is in motion.
NO COIL OVERS ALLOWED.
10. Rear leaf springs are to remain visually standard, fore and aft of the U-bolts, including shackle plates. Blocks to Max 50mm may be fitted.
11. No additional suspension adjustable devices or ballast permitted. Adjustable camber pins accepted.
12. Rear shock absorber strut towers in coupe/hatchback style cars may be braced with 25 x 25 x 3 RHS or 20NB Med C.H.S.

WHEELS

1. All wheels to be in good condition and suitable for competition.
2. Cars manufactured with different size wheel/rim options may use this option in any combination. (E.g. you may have a mix of sizes on the racecar at any time - 14" on the front, 15" on the rear etc.)
3. Maximum 6 ½" rims be allowed.
Race car to stay within track measurement, no machining of rims allowed, no modifications to outer rim.
4. The original steel wheels may be substituted by aftermarket steel wheels or alloy wheels.
5. Maximum 50mm over standard track allowed.
6. Correct wheel nuts for wheel/stud must be used.
7. Wheel Studs: The original size studs may be retained but must be in good condition. Alternately wheel studs may be upgraded to a larger size. Recommend 12mm studs minimum.
8. No welding up stud holes and re drilling new pattern in alloy or steel rims or axles.
10. No composite type rims to be used.

TYRES

1. Racing tyres or racing retreads NOT PERMITTED.
2. All tyres to be **Australian road legal** at time of purchase.
3. No tyre purchased is to exceed \$180.00 including GST as priced from a retail outlet.
4. Maximum bag width determined by the tyre manufacturer's sidewall marking not to exceed 215.
5. Cold processed retreads not permitted.
6. Restricted up to and including "V" rated RADIAL. 60 series minimum tyres only.
7. Grooving of tyres permitted TO THE ORIGINAL PATTERN ONLY.
8. If retreads are to be used, they can only be on a case up to and including 'V' rated radial 60 series minimum.

STEERING

1. The original O.E.M. or O.E.M. replacement type steering must be used.
2. Lengthening/shortening of steering arms is permitted on right hand side only to a maximum of 25mm.
3. Original diameter steering wheel or larger may be used. Minimum size to be 350mm
4. Power steering maybe used if available as OEM option.
5. Power steering oil cooler may be fitted, must remain in the engine compartment.
6. Power Head or Steering Quickener Not Permitted.

AERODYNAMIC AIDS

Rear windows not to be filled in.

Boot Spoiler - An OEM or aftermarket boot spoiler for make and model of car may be used, no higher than 180mm from boot lid surface to top of boot spoiler. Boot spoiler to be mounted by original mounting method.

STREET SEDAN CARBURETTOR LIST

Make & Model of Car	Carburetor
Torana (except HB) including 3.3 'Red'	Single Throat Stromberg
Commodore including 3.3 'Red'	Single Throat Stromberg
Commodore 3.3 'Blue'	Varijet 11
Commodore 3.3 'Black'	Varijet 11
Cortina TC & TD 6 Cyl not cross flow	Single Throat Stromberg
Cortina TD-TE-TF Cross Flow	Single Throat Stromberg
Falcon XK-XB all engines no cross flow	Single Throat Stromberg
Falcon XC-XD cross flow	Single Throat Stromberg
Falcon XE 3.3 or 4.1	Weber 34ADM
Falcon XF 3.3 or 4.1	Weber 34 ADM
Escort	Weber Down Draught 2BBL
Laser/Meteor 1.5ltr	Hitachi Down Draught 2BBL
Valiant AP5-VF all 'slant' engine	Single Throat Holley, Ball & Ball or Stromberg
Valiant VG-CM all 'Hemi' engines	Dual Throat Carter Email
Centura All models all 'Hemi' engines	Dual Throat Carter Email
Sigma All engines	Solex Down Draught 2BBL or Makuni
Galant All engines	Solex Down Draught 2BBL
Toyota All engines	Asian Down Draught 2BBL
Golf All engines	Solex Down Draught 2 BBL
Nissan Skyline	GQ Patrol Carb. & Manifold
Datsun 1600	Hitachi/Nikki Down Draught 2BBL
Datsun 4 cylinder engines	Hitachi/Nikki Down Draught 2BBL
Datsun 6 cylinder engines	Hitachi/Nikki Down Draught 2BBL
Pulsar 1.5 ltr	Hitachi Down Draught 2BBL
Mini all engines	S.U.

STREET SEDAN DIMENSIONS (including 50mm over track allowance)

Model	Wheel Base	Track		Overall Length	Overall Width
		Front	Rear		
Holden					
LJ	2540	1371	1345	4369	1600
LH/LX	2591	1447	1422	4521	1702
VB-VK	2668	1500	1470	4714	1722
VL	2668	1500	1470	4766	1722
VN	2731	1505	1530	4865	1815
VP	2731	1501	1528	4891	1812
VR-VS	2731	1541	1541	4861	1782
VT	2788	1619	1637	4884	1842
VX-VY	2788	1619	1637	4891	1842
VZ	2789	1619	1627	4876	1842
VE	2789	1619	1627	4876	1842
Ford					
TD	2581	1472	1472	4261	1702
TE	2578	1476	1476	4376	1699
TF	2580	1470	1470	4260	1710
XD	2818	1610	1576	4737	1859
XE	2790	1602	1587	4716	1859
XF	2829	1597	1575	4740	1860
EA	2794	1596	1583	4811	1857
EB-EF	2794	1604	1583	4811	1857
EL	2791	1616	1597	4918	1862
Escort	2400	1310	1330	3980	1590
AU	2793	1616	1597	4907	1870
BA/BF	2829	1603	1621	4917	1864
FG	2838	1643	1648	4955	1868
Focus	2640	1540	1536	4481	2020
Chrysler Mitsubishi					
KB/KC	2667	1457	1447	4585	1727
CL	2819	1531	1541	4975	1597
RB/RC	2380	1420	1390	3910	1590
GE/GH	2515	1420	1398		
GJ/GN	2530	1430	1400		
Toyota					
TA 22	2425	1330	1335	4165	1610
Nissan					
1600	2420	1330	1330	4120	1490
180B	2500	1360	1370	4215	1600
200B	2500	1395	1395	4260	1630
240K	2610	1410	1390	4460	1625
260Z 2+2	2605	1406	1397	4445	1630
260C	2690	1435	1430	4485	1690
280C	2690	1435	1430	4785	1690

continued

STREET SEDAN DIMENSIONS (including 50mm over track allowance)

Model	Wheel Base	Track		Overall Length	Overall Width
		Front	Rear		
Skyline 82-86	2615	1460	1450	4620	1675
Skyline R31 86 on	2610	1484	1460		
Pulsar Hatch N14	2430	1486	1471	4145	1670
Pulsar Sedan N14	2430	1486	1471	4230	1670
Mazda					
323 - 80	2315	1345	1360	3835	1605
80-82	2365	1440	1445	3955	1630

STREET SEDAN ENGINE SPECIFICATIONS

Model	Bore	Stroke	Valve	
			Intake	Exhaust
Holden				
LJ - 202	3.625	3.25	38.10	32.50
- 186	3.625	3.00	38.10	32.50
LH/LX	3.625	3.25	38.10	32.50
VB-VK	3.625	3.25	41.25	35.80
VL	3.3858	3.3464	42.10	35.10
VN	3.800	3.400	43.40	37.80
VP	3.800	3.400	43.40	37.80
VR-VS-VT-VX-VY	3.800	3.400	43.40	37.80
VZ				
VE				
Ford				
Escort	3.5748	3.0275	42.00	
TD 200/250	3.680	3.1300/3.9100	44.00	38.20
TE	3.680	3.9100	44.00	38.20
TF	3.680	3.9100	44.00	38.20
XD	3.680	3.9100	44.00	38.20
XE - XF	3.680	3.9100	44.00	38.20
XF - Late	3.680	3.9100	45.72	38.20
EA	3.6165	3.9100	47.00	39.00
EB-EF-EL	3.6322	3.9098	47.00	39.00
AU	92.2mm	99.3mm	47.00	41.00
BA	92.2mm	99.3mm	35.00	32.00
BF				
FG	92.25mm	99.31mm		
Focus	87.5mm	83.1mm		
Chrysler Mitsubishi				
KB/KC	3.760	3.680	46.72	38.10
CL	3.760	3.680	46.72	38.10
RB/RC	3.760	3.680	46.72	38.10
2.0 litre	3.3070	3.5433	43.00	35.00
2.6 litre	3.5866	3.8582	43.00	35.00
Toyota				
TA22	3.4842	3.1496	43.00	34.00
Nissan				
1600	3.2677	2.8858	38.10	32.90
180B	3.3464	3.0708	42.00	35.00
200B	3.3464	3.3858	42.00	35.00
240K	3.2677	2.9015	42.00	35.00
260Z 2+2	3.2677	3.1102	42.00	35.00
260C	3.2677	3.1102	42.00	35.00
280C	3.3858	3.1102	44.00	35.00

STREET SEDAN ENGINE SPECIFICATIONS

Model	Bore	Stroke	Valve	
			Intake	Exhaust
Skyline 82-86	3.2680	2.902	38.00	33.00
Skyline R31 86 on	3.3858	3.3464	42.10	35.10
Pulsar N14 SR20	3.39	3.39	34.00	30.00
Pulsar N14 GA16	2.992	3.465	30.00	24.00
Mazda				
323-80	2.8740	2.9921	36.00	31.00
80-82	2.8740	2.9921	36.00	31.00

SUPER

STREET

SEDANS

SPECIFICATIONS

SUPER STREET SEDANS

This class was designed as a performance variance of Street Sedans.

ENGINE BLOCKS

1. Engine to be of parent manufacture i.e. Holden to Holden, Ford-to-Ford. Over head valve to Overhead valve, Overhead cam to Overhead cam engines only.

Engine must either match model car being used or be an earlier model engine for the model car. If an earlier model engine is being used it must be positioned in the engine bay with the rear face of the block in the same position as the original engine for that model.

Maximum 6 cylinder normally aspirated and rotary engines (13B maximum) permitted. No turbo/super charged engines permitted.

2. All manufacturer's engine numbers and markings must remain on blocks.
3. Engine Restraint must be fitted if the engine mount is not solid. If resilient engine mountings are used a 6mm wire cable or 6mm chain restraint must be used.
4. Length of Stroke must match the block being used.
5. No restriction on internal engine modifications.
6. One only oil filter may be used in the original position **or** you may use a remote filter equivalent to the filter as fitted to the engine originally. Hydraulic Hose to be maximum 1 metre in length and maximum 16mm diameter. Filter must remain in engine compartment.
7. An engine oil cooler may be used, must remain in engine compartment.
8. Sumps may be altered and enlarged.
9. Dry sumping of engines not allowed.
10. Ignition system open.

CYLINDER HEAD

1. Original parent manufacturer's head of same configuration (i.e.) Ford 250 Cast Iron Cross Flow can be changed to an Aluminum Cross Flow - G.M.H. Blue Head can be used on a Red Motor.
2. SOHC: Single overhead camshaft located above or adjacent to the valves in the cylinder head and driven by the crankshaft via a metal "chain" or toothed "belt" made of neoprene or other synthetic rubber compound.

3. DOHC: Double or twin overhead camshafts located parallel to each other in the cylinder head above or adjacent to the valves, sometimes known as a "twin cam". Not to be confused with Vee formation or horizontally opposed engines that have a single overhead camshaft for each bank.

O.E.M FUEL INJECTION

1. OEM Injectors only to be used. E.g. Bosch to remain Bosch.
2. Any passenger car fuel pumps may be used.
3. Inlet Manifold - either original or aftermarket can be used. (Specially made one off manifolds not allowed) Clarification - Manifold must be able to be bolted directly onto the head without adaptation.
4. Computer Control Units are not restricted. If OEM units includes ignition, the modified or replacement CCU must also perform this function.
5. Size of throttle body; Throttle body to be OEM **type and size** for model engine being used and to be standard in INTERNAL and EXTERNAL appearance, any model car without cable throttle may be modified to fit linkages for the use of cable throttle and return springs.
6. Fuel to be supplied from any commercial outlet through any multi volume network via bowser pump. To be a maximum Sg 0.780. (Sg to be measured at 15 degrees Celsius) No exotic or racing fuels or additives eg. ELF, VP etc
7. If a Fuel Pressure gauge is used it must be mounted in the boot area or in engine compartment.
8. Return springs must be fitted to each butterfly shaft (in built springs accepted), and one spring to accelerator pedal linkage.
8. Non OEM Fuel Injection NOT permitted - forced induction NOT permitted.

CARBURETOR

1. Carburetor. A single carburetor with a maximum of two (2) venturis to be used (no multiple carburetors) Max. 500 cfm.
2. Inlet Manifold. If a two venturi manifold is available for the type of engine being used, either original manufacturer or aftermarket, it can be used. (Specially made manifolds not allowed.)
3. Carburetor must work as intended and retain needle valve and seat and air/fuel metering.
4. Air cleaners to suppress backfire must be used.

5. Two springs must be fitted at two separate points on throttle linkage, one at butterfly shaft and one at pedal linkage.
6. Fuel System. Fuel pumps may be changed or modified.
7. Fuel to be supplied from any commercial outlet through any multi volume network via bowser pump. To be a maximum Sg 0.780. (Sg to be measured at 15 degrees Celsius) No exotic or racing fuels or additives eg. ELF, VP etc.
EXCEPTION – AV Gas may be used.

EXHAUST

1. Exhaust systems may be modified and have a maximum of two (2) outlet pipes.
2. Exhaust noise must be muffled to be within local Government authority levels to Max 95dba.
3. Pipes must extend past driver and passenger seat and be directed away from fuel tank, tyres and other competitors.
4. Muffler and Exhaust Pipe must be chained to body in two (2) places with minimum 6mm Chain.
5. Muffler and Exhaust Pipe must be chained to body with min 6mm chain.
6. Heat dispersant coatings on the outside of the exhaust manifold are acceptable but no coating allowed on the inside.

TRANSMISSION

1. Gearbox housing must be as per parent manufacture. Aftermarket bell housing may be used. Ratios may be changed. Automatic transmission may have torque converter removed.
2. Clutch and Flywheel **MUST** be retained and operational but may be modified and upgraded.
3. The original type differential housing must be used but housing tube may be altered 50MM max. (i.e.) Banjo to remain Banjo.
Differential must bolt up to the original mounting points.
Crown wheel and pinion may be changed provided no modification to housing to allow fitment.
Differentials may be locked.

SUSPENSION

1. The original type suspension must be retained using ALL the entire original mounting points in the original position.
2. All cars to use O.E.M cross member only.
3. Suspension may be modified and upgraded.
4. No additional components permitted: Stabiliser Bars, Shock Absorbers, and Panard Bars etc. Both ends of the Panard Bar to be in the original mounting position where fitted as standard equipment. Watts link, where fitted, to be mounted in the original position.
5. Shock absorbers may be upgraded. No coil over units allowed.
6. Weight jacking systems incorporated into the spring mountings are permitted but are not to be adjustable whilst car is in motion.
7. Rear leaf springs are to remain visually standard, fore and aft of bolts, including shackle plates. Blocks to Max. 50mm may be fitted.
8. No additional suspension adjustable devices or ballast permitted. Adjustable camber pins accepted.
9. Rear shock absorber strut towers in coupe/hatchback style cars may be braced with 25 x 25 x 3 RHS or 20NB Med C.H.S.

STEERING

1. The original type steering must be used (i.e.) Rack remains Rack.
2. Modifications are permitted to change the ratio provided original parts are used.
3. Original diameter steering wheel or larger may be used. Minimum size to be 350mm
4. Power steering maybe used if available as OEM option for model being used.
5. Power steering oil cooler may be fitted, must remain in the engine compartment.
6. Power head or steering Quickener not permitted.

WHEELS

1. All wheels to be in good condition.
2. Maximum 7" wheels allowed.
3. Diameter of wheels can be changed.
4. Correct wheel nuts for wheel must be used.
5. Wheel Studs: The original size studs may be retained but must be in good condition. Alternately wheel studs may be upgraded to a larger size. Recommended to upgrade to 12mm studs minimum.
6. No welding up stud holes and re-drilling new pattern in alloy or steel rims and axles.
7. No composite type rims to be used.
8. The original steel wheels may be substituted with aftermarket steel or alloy wheels. Maximum 75mm over standard track allowed. Refer to Pages 48 & 49.
9. Conversion of hubs from 4 to 5 stud systems is allowed. Listed below are a number of systems that have been approved for this, we recommend that you follow one of these ways in carrying out your conversion. If you require further information please contact your Club Machinery Examiner firstly then your Zone or State Technical Rep.
 - a. Castlemaine Rod conversion for front stub axles.
 - b. Bryan Zelinski diff conversion.
 - c. Diff centre and axles - **suit TF Cortina**
 - i. Left hand side axle Ford 5 stud 28 spline.
 - ii. Right hand side Holden 5 stud 28 spline.
 - iii. Diff centre will have 28 spline mini spool fitted.
 - iiii. Brakes to remain standard Cortina.
 - d. To **suit TE Cortina**
 - i. Front - Toyota Crown hub and rotors (10mm to be machined off the circumference to the rotor) with TE calipers.
 - ii. Left rear - XA Falcon short axle, brake drum, brake shoes and backing plate.
 - iii. Right rear - VH Valiant short axle and brake drum, XA Falcon brake shoes and backing plate.
 - e. XA Falcon drum brake hub with an EA Falcon rear disc hat.
 - f. Centura five stud front hubs.
 - g. Standard Falcon brakes, Cortina diff housing unaltered, diff centre welded with side gears moved to accommodate short Falcon axles.
 - h. To **suit TD Cortina**

Axle tubs modified to suit larger bearings. Axle to suit housing modification. Brakes to remain drums compatible with axles being used.

TYRES

1. Maximum bag width determined by the tyre manufacturer's sidewall marking not to exceed 245. E.g. Tyres to read on the sidewall – 245/60 x 15 – 84/8x15.
2. Cold processed retreads are not permitted.
3. Grooving of tyres permitted.

AERODYNAMIC AIDS

1. It is an option to fit a roof wing.
2. Two front mounting points to be welded to steel head plate or roll cage.
3. Two rear mounting points to be welded to roll cage rear brace bars.
4. Wing mounts to be Min. 25 x 25 x 3mm RHS. or equivalent.
5. Rear mountings to have cross brace Min. 25 x 6mm FMS.
6. Safety chains or cable of 6mm gauge Min. or equivalent to be fitted to wing at all four corners at separate points on roll cage.
7. Wing to be no bigger than roof. Measurement of roof determined at centre/top of windscreen to centre/top of rear window and from inside LH gutter trim to inside RH gutter trim.
8. Side of wing panel to be no higher than the height of the door skin (i.e.) bottom of doorskin to top of doorskin.
9. Side panel not to cover window openings.
10. Wing may be moved back from top of windscreen to a Max. of 450mm but must not protrude past the rear body line of car.
11. Wing must not be forward of top of windscreen.
12. Sides of wing to be suitably stayed to main part of wing.
13. Roof number to be mounted to a stay bar, to be fitted from the RH side of wing to the front top of LH side of wing. Brace to be 25 x 25 x 3mm R.H.S. or 50 x 5mm FMS or equivalent. Mounts on wing to be suitably reinforced.
14. A V8 Super car wing may be used on Falcons and Commodores. The mounting method must be securely attached to prevent it becoming a danger. Wing is to be not more than half rear window height.

BOOT SPOILER

1. A boot spoiler may be used **in lieu** of a roof wing.
2. If spoiler is made of metal or fibreglass, centre section to be no higher than half the rear window on a horizontal plane. (see diagram Page 61)
3. Sides of spoiler to taper from top of centre section to bottom of rear window.
4. All parts of spoiler to be inside bodyline.
5. Boot spoilers must not hinder access to fuel tank in the event of fire.
6. No other aerodynamic aids permitted.

REAR SPOILER - SUPER STREET SEDAN

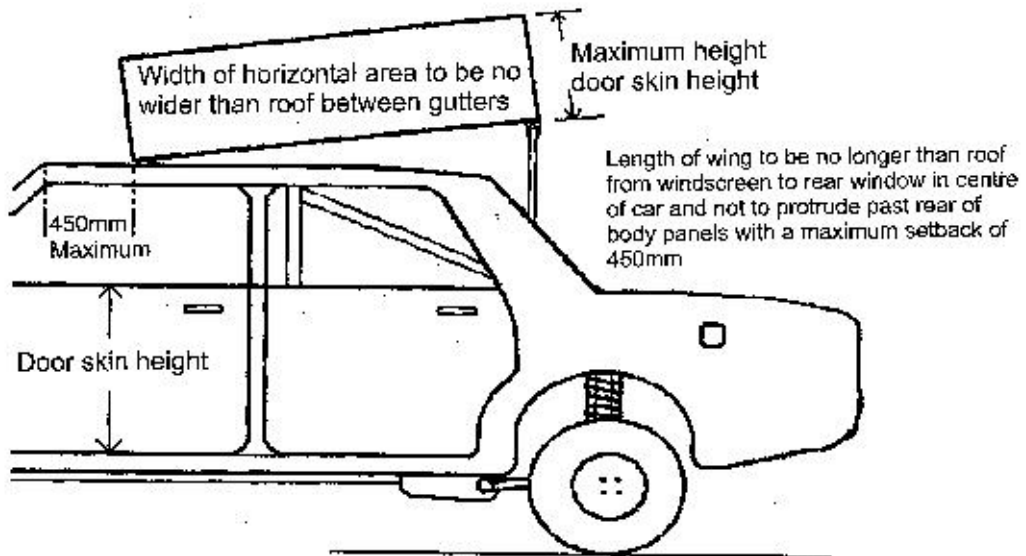
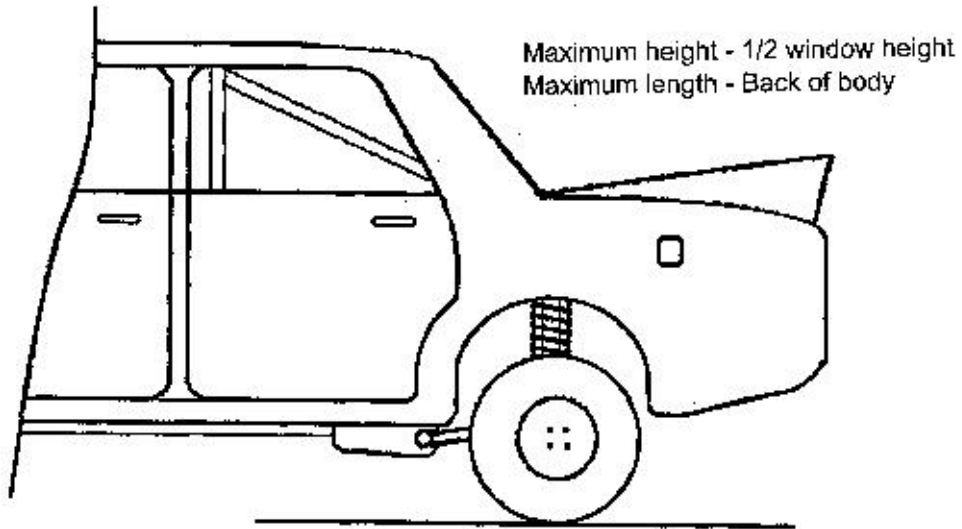

SUPER STREET SEDAN WING OPTION - instead of spoiler

SUPER STREET SEDAN DIMENSIONS (including 75mm overtrack allowance)

Model	Wheel Base	Track		Overall Length	Overall Width
		Front	Rear		
Holden					
LJ	2540	1396	1370	4369	1600
LH/LX	2591	1472	1447	4521	1702
VB-VK	2668	1525	1495	4714	1722
VL	2668	1525	1495	4766	1722
VN	2731	1530	1555	4865	1815
VP	2731	1526	1553	4891	1812
VR-VS	2731	1566	1566	4861	1782
VT	2788	1644	1662	4884	1842
VX – VY	2788	1644	1662	4891	1842
VZ	2789	1644	1652	4876	1842
VE	2915	1677	1693		
Ford					
Escort	2400	1335	1355	3980	1590
TD	2581	1497	1497	4261	1702
TE	2578	1501	1501	4376	1699
TF	2580	1495	1495	4260	1710
XD	2818	1635	1601	4737	1859
XE	2790	1627	1612	4716	1859
XF	2829	1622	1600	4740	1860
EA	2794	1621	1608	4811	1857
EB-EF	2794	1629	1608	4811	1857
EL	2791	1641	1622	4918	1862
AU	2793	1641	1622	4907	1870
BA/BF	2829	1628	1646	4917	1864
FG					
Focus	2640	1565	1561	4481	2020
Chrysler Mitsubishi					
KB/KC	2667	1482	1472	4585	1727
CL	2819	1556	1566	4975	1597
RB/RC	2380	1445	1415	3910	1590
GE/GH	2515	1445	1423		
GJ/GN	2530	1455	1425		
Toyota					
TA 22	2425	1355	1360	4165	1610
Nissan					
1600	2420	1355	1355	4120	1490
180B	2500	1385	1395	4215	1600
200B	2500	1420	1420	4260	1630
240K	2610	1435	1415	4460	1625
260Z 2+2	2605	1431	1422	4445	1630
260C	2690	1460	1455	4485	1690
280C	2690	1460	1455	4785	1690

continued

SUPER STREET SEDAN DIMENSIONS (including 75mm over track allowance)

Model	Wheel Base	Track		Overall Length	Overall Width
		Front	Rear		
Skyline 82-86	2615	1485	1475	4620	1675
Skyline R31 86 on	2610	1509	1485		
Pulsar Hatch N14	2430	1511	1496	4145	1670
Pulsar Sedan N14	2430	1511	1496	4230	1670
Mazda					
323 - 80	2315	1370	1385	3835	1605
80-82	2365	1465	1470	3955	1630

GLOSSARY OF TERMS

- APPROVED MATERIALS:** Fibreglass, Race Plastic, Steel, Aluminium
- AFTERMARKET:** Parts that are used that are non genuine or OEM.
- AMENDMENT:** An alteration to the specifications as set out in this manual, circulated to Clubs/car owners/club scrutineers.
- ASCF/SSA Inc:** ASCF Speedway Sedans Inc - the national body of registered speedway sedans in Australia.
- C.H.S.:** Circular Hollow Section.
- CLUB:** A body affiliated with the Q.S.C.A. Inc
- DAYLIGHT INSPECTION:** An inspection made prior to initial registration, when Log Book is full, race car changes hands or when requested by the QSCA Inc State Technical Rep.
- EARLY MODEL ENGINE/LATE MODEL CARS:**
An engine that was produced prior to the model car being used.
- ENGINE:** Any part of the engine that helps make it operate is deemed to be part of the engine componentry. e.g. manifold, carburetor, key, etc.
- IMPOUND AREA:** A designated area set aside for the inspection of car/cars as required by the State Technical Rep/Committee.
- MANAGEMENT COMMITTEE:** A committee made up of elected persons to control the affairs of the QSCA Inc for a period between elections (usually 1 year).
- O.E.M.:** Original equipment manufacture.
- PERFORMANCE VARIATION:**
If a part is available as an OEM Replacement part, sold through an Australian retail outlet, the OEM or replacement option for the model being used must meet specification in all componentry then it may be used.
- PRACTICE:** Any official time set aside for the use of the racetrack for racecars - before, during or after a race meeting or at any other time as designated by the Promotion.
- Q.S.C.A. Inc** The Queensland Saloon Car Association Inc - the controlling body of registered speedway sedans in Queensland.

- RACE MEETING:** Any official meeting at any registered track as designated by the Promotion.
- RACEWEAR APPROVALS:** A list of items that have been checked and approved for use whilst taking part in QSCA Inc/ASCF/SSA Inc events.
- R.H.S.:** Rectangular Hollow Section
- Sg:** Specific Gravity.
- SINGLE:** Singular - one only.
- STATE TECHNICAL REP.:** A person elected to control the specifications for QSCA Inc registered cars and also to educate the elected Club Scrutineers and be in charge of scrutineering at State Titles and any other occasions as directed or required.
- TECHNICAL COMMITTEE:** Made up of three Zone Technical Reps and the two State Technical Reps – Chairperson to be QSCA Vice President and Secretarial Duties completed by Treasurer.
- WINDOW NET:** A stitched webbing which fills the majority of the window opening to prevent items from intruding into of the cabin.
- W.T.:** Wall thickness.
- ZONE TECHNICAL:** A person elected to control scrutineering and specifications in their appointed zone.